

Form Service & Warranty Claim

DT SWISS

*This is an electronic form
Can be filled in electronically*

DT Swiss HUBS

Reference Number:

(Do not fill in this number)

Date:

**Please Service
Warranty Claim**

Contact Distributor / Dealer:

Name Distributor / Dealer*:

ZIP / Address*:

Country*:

Phone*:

Fax*:

E-mail*:

Customer's name*:

Sales receipt enclosed?

Yes

No

**In case the rework cannot be done
under warranty, do you want us to
contact you for an estimation of
cost prior to service the product?**

Yes

No

Hub model (e.g. 370, 240s, FR440 etc.):

Serial number hub*:

Please describe precisely the hub's failure by marking the box(es).

Broken / Damaged / Cracked hubshell

Bearing play / Worn bearings

Coating damage / Corrosion

Free wheel system damage
(Star Ratchet or 2-Pawl system)

Strange noise while riding (creaking etc.)

Others

Mark spot of failure in drawing to speed up your service! Thank you!

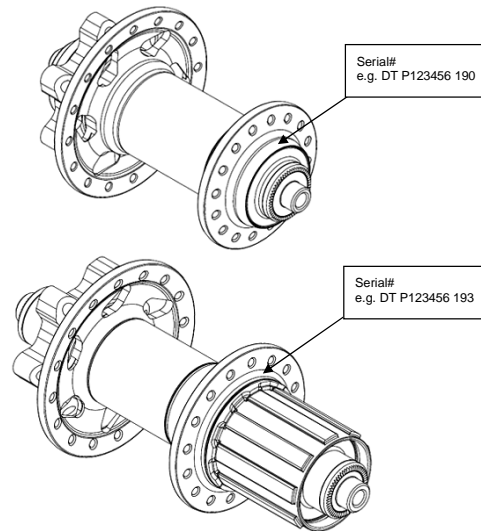

NOTE:

- Remove the hub's quick release before sending the shock! The DT Swiss Service Center will not be responsible for lost QR's!.
- One complete Service & Warranty Claim form must be added per service / warranty claim!
- The DT Swiss Service Center will reject incomplete Service & Warranty Claims (e.g. missing sales receipt etc.)!
- For further information please read the DT Swiss Owners Manual of this product concerning DT Swiss Warranty regulations or visit www.dtswiss.com.